

DODGE JOURNEY



DODGE

MEET THE ALL-NEW DODGE JOURNEY.

It's that rare blend of value, versatility and performance that fuels this blend of confidence.





JOURNEY: REDEFINED.

Dodge engineers have redesigned Journey inside and out and give you all the style, technology and versatility that you need without sacrificing its identity. Journey's all-new shield and bright crosshair grille design with black mesh is the definition of bold. Its sculpted fender flares and muscular lines emphasise a sporty and athletic appearance. The all-new jewelled LED tail lamp design shows that great attention to detail radiates in every facet of Journey. It's clear that Journey is in a class of its own. It sets a standard that others fail to meet.





Journey SXT shown in Brilliant Red



ROOM TO MOVE.

Journey's interior is beyond flexible and always compatible with your ever-changing lifestyle. With the standard seven-passenger seating, featuring a 60/40 split-fold-flat stadium-style second-row seat and a 50/50 split-fold-flat third-row seat, everyone travels in comfort. Stepping inside Journey is easy. The rear doors open 90 degrees and the standard Tilt 'n Slide™ second-row seat creates an even easier entry to the third-row seats. The standard Keyless Enter 'n Go™ automatically unlocks the vehicle when the key fob is with you and you pull on the door handle. It also recognises when your vehicle's key fob is in the vehicle compartment and lets you start the engine

with one press of the Go button. Journey not only carries passengers in style, but also keeps the things they carry amazingly organised. An easy-to-access centre floor console features cup holders, 12-volt power outlets, remote USB port, auxiliary power outlet and out-of-view storage. Two in-floor storage bins with lids each hold up to a dozen 340 ml cans plus ice or other travel items in a removable liner. The standard Flip 'n Stow™ fold-flat front-passenger seat features a storage bin under the hinged seat cushion. When hauling gear is the priority, fold down the seats for an impressive 1461 litres of cargo capacity.



IN-FLOOR STORAGE. Keep your items safe from prying eyes with Journey's extra storage areas.



1. LEATHER-WRAPPED STEERING WHEEL. Journey showcases an all-new three-spoke steering wheel with bold new shield and crosshair Dodge logo design. It features cruise controls at the front of the steering wheel and audio controls at the back. **2. WIDE ARM REST.** The armrest on Journey has been widened and lengthened for additional soft-touch comfort and more space to rest your forearms. **3. REDESIGNED CENTRE CONSOLE.** Journey's full-length floor centre console features two electroluminescent cup holders, Media Centre auxiliary jack and USB port, a new dual-action lid, 12V outlet and additional storage space.

Journey R/T model interior shown with optional navigational radio.

POWER TO IMPRESS.

JOURNEY PERFORMANCE. From state-of-the-art aluminium block casting to full four-cam phasing to ultrafast data processing and torque based engine management, the standard all-new 3.6-litre Pentastar® V6 engine applies some of the most advanced automotive engine technology. The result is an exceptional

blend of high torque, fuel economy, low emissions, and first-rate noise, vibration and harshness control. The only thing better than numbers like 206 kW of power and 342 N.m of torque is the engine's durability enhancing features that require very low maintenance.



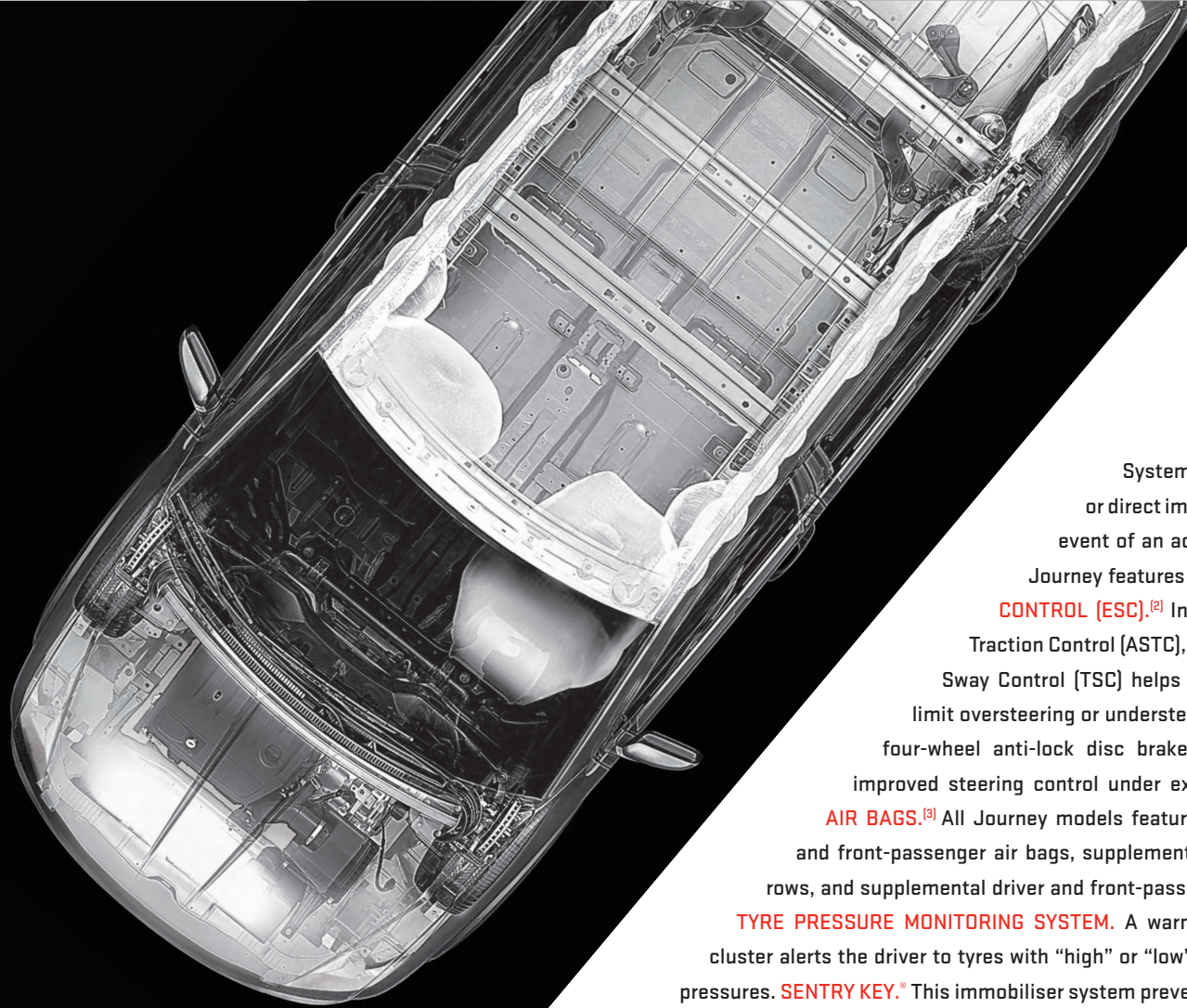

SAFETY & SECURITY.

Systems like crush zones and safety-cage construction work together to absorb or direct impact energy away from the passenger compartment in the unfortunate event of an accident. For children who have outgrown aftermarket child seats, Journey features dual integrated child booster seats.⁽¹⁾ **ELECTRONIC STABILITY-CONTROL (ESC).**⁽²⁾ In adverse conditions, the system, which includes All-speed Traction Control (ASTC), Brake Assist, Electronic Roll Mitigation (ERM) and Trailer Sway Control (TSC) helps the driver maintain vehicle directional stability and limit oversteering or understeering. **ANTI-LOCK BRAKE SYSTEM (ABS).** Standard four-wheel anti-lock disc brakes sense and control wheel lockup, offering improved steering control under extreme braking and/or slippery conditions. **AIR BAGS.**⁽³⁾ All Journey models feature standard advanced multi-stage driver and front-passenger air bags, supplemental side-curtain air bags for all three rows, and supplemental driver and front-passenger seat side-mounted air bags. **TYRE PRESSURE MONITORING SYSTEM.** A warning system in the instrument cluster alerts the driver to tyres with “high” or “low” displays for individual tyre pressures. **SENTRY KEY.®** This immobiliser system prevents unauthorised vehicle operation by disabling the engine. Operation is automatic, regardless of whether the vehicle is locked or unlocked. **HILL START ASSIST (HSA).** Automatically applies the brakes momentarily to help prevent rollback on hills and inclines.

(1) For children 22-38 kg and up to 145 cm. (2) No system, no matter how sophisticated, can repeal the laws of physics or overcome careless driving actions. Performance is limited by available traction, which snow, ice and other conditions can affect. When the ESC warning lamp flashes, the driver needs to use less throttle and adapt speed and driving behaviour to prevailing road conditions. Always drive carefully, consistent with conditions. Always wear your seat belt. (3) Always sit properly in the seat with the seat belt fastened. Always observe the passenger air bag indicator lamp to determine if the Occupant Classification System (OCS) is appropriate. Children 12 and under should always be in the backseat correctly using an infant or child restraint system or the seat belt positioned correctly for the child's age and weight.

GENUINE DODGE ACCESSORIES.

When your Journey is outfitted with Genuine Dodge Accessories by Mopar, its stylish, eye-catching profile becomes uniquely you. All Mopar products are specifically designed to enhance your vehicle, making it a creation of distinction and flair. When it comes to the fit, finish and functionality of accessories for your Journey, choose only those that befit a legendary brand. For a full list of Genuine Dodge accessories, please visit your local authorised Dodge dealer.



1. RUBBER SLUSH MATS.



2. DOOR SILL GUARDS.



3. SUNROOF DEFLECTOR.



4. 19-INCH CAST ALUMINIUM WHEELS.

GENUINE DODGE ACCESSORIES





Genuine Dodge Accessories by Mopar give your Journey style and protection that stands out. Genuine Journey accessories shown above: **19-INCH CAST ALUMINIUM WHEEL CHROME BODYSIDE MOULDINGS**. Add a little personality with chrome accents. Mouldings sold in set of four. **CHROME FUEL FILLER DOOR**. A bright complement to any body colour. Replaces existing fuel filler door. Features easy, no-drill installation and smooth door operation. For a full list of Genuine Dodge accessories, please visit your local authorised Dodge dealer.



STAY CONNECTED.

THIS IS UCONNECT.™ It helps you stay in touch with the people, music and devices that matter most. It acts as the hub for your most important media i.e. mobile phone and personal devices such as an iPod.® The available Uconnect user-friendly systems are designed to make your life easier, wherever you roam.



UCONNECT PHONE.⁽¹⁾ An in-vehicle, voice-activated communication system that allows you to pair up to seven Bluetooth® compatible phones and then talk virtually hands-free. This system is also clever enough to synchronise with your phone's address book with up to 1000 entries.



VOICE COMMAND.⁽²⁾ It simplifies driving by letting you keep your eyes on the road and your hands on the wheel. Vocally select radio stations, make and receive calls, select navigation⁽³⁾ destinations and record voice memos. This smart system technology can also be trained to better recognise your voice and can understand commands in English, Dutch, French, German, Italian and Spanish.



ENTERTAINMENT. Manage all of your media with six ways to access audio, integrated built-in hard drive, iPod® Control, Voice Command⁽¹⁾ and Bluetooth® streaming audio which allows you to play digital audio files stored in your mobile device through the vehicle's speakers.



NAVIGATION.⁽³⁾ Enjoy safe travels with GPS Navigation, providing voice guidance and visual display. It can also locate nearby petrol stations, restaurants, shopping, hospitals or points of local interest.

Navigation radio is optional on R/T.

PAINT.

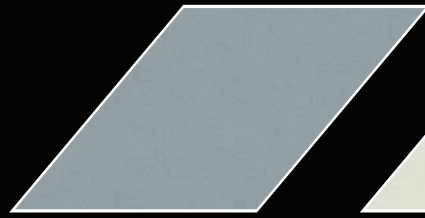

BRIGHT SILVER

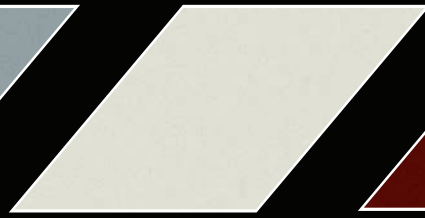

PEARL WHITE

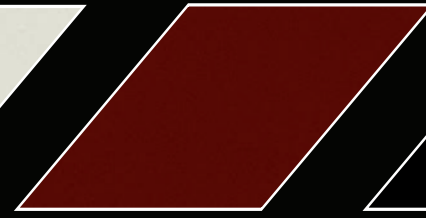

COPPERHEAD

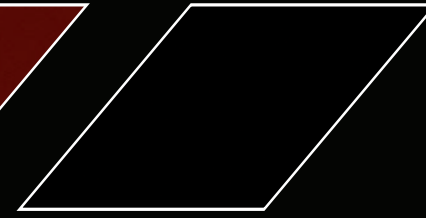

BRILLIANT BLACK

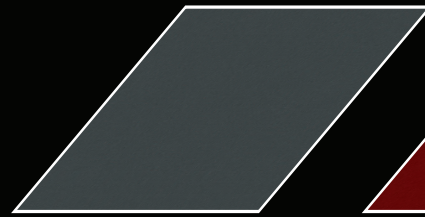

STORM GREY

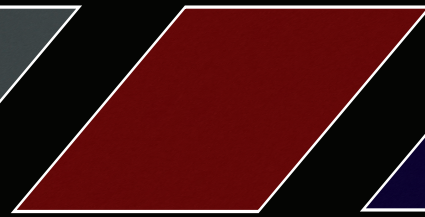

BRILLIANT RED

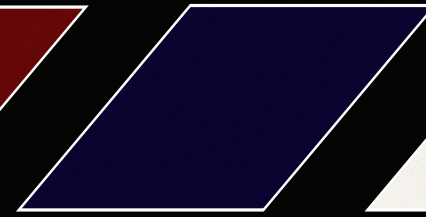

BLUE PEARL

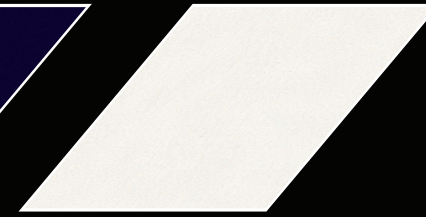

WHITE

WHEELS.



17-inch aluminium wheels (standard on SXT)



19-inch aluminium wheels (standard on R/T)

Note: Due to the printing process, the colours shown may vary slightly from actual hues.

JOURNEY TECHNICAL SPECIFICATIONS

POWERTRAIN

Engine	3.6L V6 24V VVT
Displacement (cc)	3604
Power (kW @ rpm)	206 @ 6350
Torque (N.m @ rpm)	342 @ 4350
Bore x Stroke (mm)	96 x 83
Compression Ratio	10.2:1
Alternator	160 amp
Service Interval, Primary (km)	12 000
Battery	525 amp maintenance free
Fuel System	Sequential multipoint electronic fuel injection

TRANSMISSION

6-speed automatic with overdrive, adaptive electronic control, electronically modulated converter clutch.

CAPACITIES/WEIGHTS (kg unless otherwise specified)

Fuel Tank (L)	77.6
Base Kerb Weight	
3.6L V6 (SXT/RT)	1942
Gross Vehicle Mass (GVM)	2472

BODY/SUSPENSION/CHASSIS

Body Design

Unitised steel construction with a structural safety cage utilising advanced hot-stamped, tailor-rolled, dual-phase steel technologies and advanced joint design for added strength, reduced weight and improved Noise Vibration and Harshness (NVH) levels

Suspension

Independent MacPherson struts with cast lower control arms, stabiliser bars and high-strength steel coil springs ___ Front
Independent rear suspension with stabiliser bar and coil-over rear shock-absorbers. _____ Rear

Steering

Firm feel rack and pinion _____ Std
Turns (lock-to-lock) _____ 2.9
Turning diameter (m) _____ 10.0

BRAKE SYSTEMS

Four Wheel Disc (Vented front/Solid rear) (mm) _____ 302/305

Electronic Stability Control (ESC)⁽¹⁾

Four-channel, four-wheel anti-lock brakes with active wheel-speed, vehicle-speed, steering-wheel angle, yaw-rate and lateral-acceleration sensors, vehicle stability management with two-stage activation switch, All-Speed Traction Control (ASTC), Brake Assist, Electronic Roll Mitigation (ERM) and Trailer Sway Control (TSC)

INTERIOR DIMENSIONS (mm unless otherwise specified)

Head Room, first/second/third row	1037/995/958
Leg Room, first/second/third row	1036/854/596
Shoulder Room, first/second/third row	1460/1448/1237
Hip Room, first/second/third row	1368/1379/1016
Cargo Volume (L), all seats in place (top of headrest)	167
Second and third row folded	1461
Seating Capacity	7 Adults

EXTERIOR DIMENSIONS (mm unless otherwise specified)

Length

Wheelbase	2890
Overall Length	4888
Overhang, front/rear	989/1009

Width

Body width	1878
Track, front/rear	1571/1582

Height (including roof rails) _____ 1745

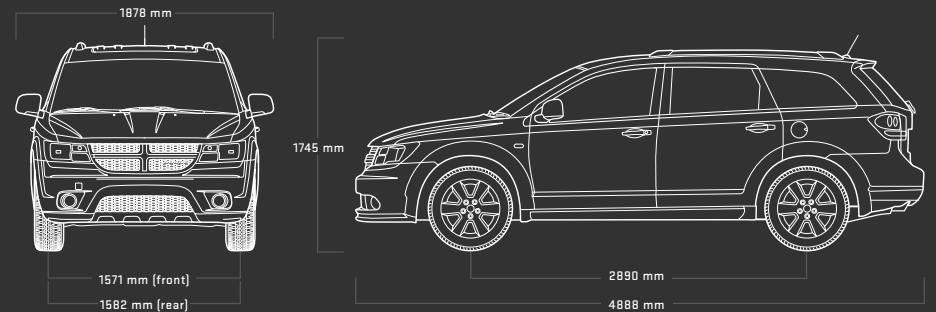

FUEL CONSUMPTION (Combined cycle litres per 100 km)

Model	Consumption	CO ₂
3.6 Auto	10.4	242

- Carbon dioxide (CO₂) is the main greenhouse gas responsible for global warming
- Actual fuel consumption and CO₂ emissions depend on factors such as traffic conditions, vehicle condition and how you drive

(1) No system, no matter how sophisticated, can repeal the laws of physics or overcome careless driving actions. Performance is limited by available traction, which snow, ice and other conditions can affect. When the ESC warning lamp flashes, the driver needs to use less throttle and adapt speed and driving behaviour to prevailing road conditions. Always drive carefully, consistent with conditions. Always wear your seat belt.

FEATURES & OPTIONS

	SXT	R/T
ENGINE		
Powertrain 3.6L V6 24V VVT engine, 6-speed automatic transmission with Auto-Stick manual shift mode	•	•
EXTERIOR		
Accents Body-colour door handles and black side roof rails	•	
Bright door handles, side roof rails and dual exhaust tips		•
Lighting Quad RHD Optic headlamps with levelling system	•	•
Front and rear fog lamps	•	•
Mirrors Power heated foldaway	•	•
Sunroof Power with express open/close		O
Tyres 225/65R17 BSW touring tyres	•	
225/55R19 BSW touring tyres		•
Wheels 17-inch aluminium	•	
19-inch aluminium		•
Wiper System Front: Variable intermittent windshield wipers	•	•
Rear: Window wiper/washer	•	•
INTERIOR		
Accents Highline door trim panel	•	
Premium door trim panel		•
Air Conditioning Three-zone Automatic Temperature Control (ATC) with air filtration	•	•
Cargo Area Carpeted folding rear seatbacks and floor, cargo cover, storage bin and cargo tie-down loops	•	•
Console Overhead front with two aimable LED lamps	•	•
Full-length front floor console with armrest, illuminated cup holders, leather-wrapped shift knob	•	•
Cruise Control Electronic, wth steering wheel mounted controls	•	•
Electronic Vehicle Information Centre (EVIC) Includes temperature and compass gauge; traveller/mini-trip computer; Tyre Pressure Monitoring (TPM) display	•	•
Latch Lower anchors and tether for child seats	•	•
Lighting Instrument panel courtesy, cargo compartment, map/dome reading and rear dome lamps	•	•
Front and rear swivelling LED lamps	•	•
Mirrors Auto-dimming rearview	•	•
Interior conversation mirror	•	•
Power Outlets 12-volt auxiliary in instrument panel and centre console and 12-volt front and rear	•	•
Seating Fabric Premium cloth seats	•	
Part-leather seats	O	•

	SXT	R/T
Seating Fabric Premium cloth seats	•	
Part-leather seats	O	•
Seating - Front Heated front seats		•
6-way driver power seat adjustment and 4-way power lumbar adjustment	•	•
Front passenger forward fold-flat seat	•	•
Seating - Second Row Easy entry 60/40 Tilt 'n Slide™ seat with recline	•	•
Second-row seat with two child boosters	•	•
Seating - Third Row 50/50 fold-flat seat with recline	•	•
Steering Column Tilt/telescopic steering column	•	•
Steering Wheel Leather-wrapped steering wheel with audio controls	•	•
Storage Front-passenger Flip 'n Stow™ in-seat storage	•	•
Second-row in-floor storage bin with latchable lids and removable liners	•	•
In-floor storage in cargo area	•	•
Windows Power with driver one-touch auto-down	•	•
SAFETY AND SECURITY		
Active Head Restraints Driver and front-passenger	•	•
Air Bags⁽¹⁾ Next generation driver and front-passenger	•	•
Supplemental side curtains for all rows	•	•
Supplemental driver and front-passenger seat-mounted side air bags	•	•
Brakes 4-wheel disc anti-lock brake system (ABS)	•	•
Electronic Stability Control (ESC)⁽²⁾ Includes Brake Assist, All-Speed Traction Control (ASTC), Electronic Roll Mitigation (ERM) and Trailer Sway Control (TSC)	•	•
Power Door Locks Speed-sensitive	•	•
Keyless Enter-N-Go Push-button ignition system with proximity entry	•	•
Security Alarm Monitors doors, flipper glass and liftgate; includes Sentry Key engine immobiliser	•	•
Tyre Pressure Monitoring Display System	•	•
UCONNECT MULTIMEDIA		
Audio System 6 speakers	•	
Premium Audio System with 6 speakers, subwoofer with 368-watts amplifier		•
Media Centre Radios Uconnect Touch 4.3 CD/MP3 radio with 4.3-inch touch screen and audio jack and remote USB port	•	•
PACKAGES		
Rear Seat Video Group I Second row overhead 9-inch video screen, video remote control and wireless headphones		P
Media Centre Radios Uconnect Touch 8.4N CD/DVD/MP3/NAV ⁽⁴⁾ radio with 8.4-inch touch screen, audio jack and remote USB port and SD card slot, hands-free communication system with Address Sync, Bluetooth and Voice Command ⁽⁵⁾ and ParkView [®] Reversing Camera ⁽⁶⁾		P

• = Standard O = Optional P = Package

(1) Always sit properly in the seat with the seat belt fastened. Always observe the passenger air bag indicator lamp to determine if the Occupant Classification System (OCS) is appropriate. Children 12 and under should always be in the backseat correctly using an infant or child restraint system or the seat belt positioned correctly for the child's age and weight. (2) No system, no matter how sophisticated, can repeal the laws of physics or overcome careless driving actions. Performance is limited by available traction control, which snow, ice and other conditions can affect. When the ESC warning lamp flashes, the driver needs to use less throttle and adapt speed and driving behaviour to prevailing road conditions. Always drive carefully, consistent with conditions. Always wear your seat belt. (3) Always check entire surroundings before reversing. (4) Never programme while driving. GPS mapping may not be detailed in all areas or reflect current road regulations. See dealer for details. (5) Must use Bluetooth[®] compatible phone. (6) Requires Uconnect phone.



3-year/100 000 km Warranty.
All vehicles are covered by the Chrysler
3-year/100 000 km
Full Maintenance Contract.
See dealer for more information.



Chrysler Financial delivers Chrysler, Jeep®
and Dodge customers a personal
automotive financing experience.
Visit www.chryslerfinance.co.za or your Dodge dealer to
discover all that Chrysler Finance and Insurance offers.



Enhance your vehicle with
Authentic Accessories by Mopar.
Designed specifically for your vehicle, for
exceptional fit, finish and performance.
Visit your dealership or www.mopar.co.za



This suite of integrated digital systems
bundles entertainment, information
and communication.
For further details, visit your dealer.



www.dodge.co.za

About this catalogue: Since time of printing, some information in this catalogue may have been updated. Ask your dealer for details. Some of the equipment shown or described throughout this catalogue is available at extra cost. Specifications, descriptions and illustrative materials contained herein are as accurate as known at the time this publication was approved for printing. Chrysler Group LLC reserves the right to discontinue models at any time or change specifications without notice or without incurring obligation. All options are required in combination with other options. For the price of the model with the equipment you desire, or verification of specifications contained herein, see your Dodge dealer. Dodge, Chill Zone™, Mopar, MusicGate Power and VES are registered trademarks and Uconnect is a trademark of Chrysler Group LLC. Boston Acoustics is a registered trademark of Boston Acoustics, Inc. iPod is a registered trademark of Apple, Inc. All rights reserved.

MODEL YEAR 2012, January 2012 (PNJC49_2012_AA)