



PRO WING® SPEEDSTILE RETRACTABLE



BoomGate
Systems (PTY) LTD
Reg.No. 98/23505/07 Engineering Access Control



MARKET LEADER

- This versatile product is suitable for most entrance control.
- Boomgate Systems offer a wide range of options to compliment any prestige installation.
- Exported worldwide.



APPLICATIONS:

- Banks, reception areas, airports, leisure facilities, museums and railway stations.
- Any application where high volume access needs to be controlled with a medium level of security.

DESIGNED FOR:

- Interior or covered exterior.
- Extreme access control with high through put.

CONFIGURATIONS:

- Narrow Lane - Gate opening 540mm
- Wide Lane - Gate opening 850mm
- Suitable for special needs access

TECHNOLOGY:

- 12V DC
- Intelligent IR Beam detection
- Tailgating
- Direction Control
- Tampering

FEATURES:

Cabinets available:

- Brushed Stainless Steel 304 / 316
- All external surfaces have a smooth brush finish
- Granite tops available on request
- Have indicators to indicate lane open/close and direction control

Glass:

- 8MM toughened glass SABS manufactured with CNC Technology



SPECIAL DESIGN FEATURES FOR THE PRO WING® SPEEDSTILE RETRACTABLE

- The modular compact design with removable access door allows for easy installation and maintenance.
- The Pro Wing® Speedstile is designed with user safety in mind; there are no sharp edges or rough surfaces.
- All external surfaces have a smooth brush finish.
- Manufacturers warranty:
 - 3 year mechanical warranty
 - 1 year electrical warranty





TECHNICAL SPECIFICATION:

ELECTRICAL REQUIREMENTS:

Power:	220V AC \pm 5%
Frequency:	50Hz
Power Consumption:	300W per lane
Power Fail Options:	Glass wings released on power failure to be moved into cabinet.
Fire Evacuation Mode:	Gate will remain open when evacuation trigger input is latched.
System Integration:	Can integrate with any access control or ticketing systems.
Cycle Time:	Open 1 second Close 1 second
Tamper Alarm:	Internal buzzer and N/O Output to security control room. <ol style="list-style-type: none">1. Tailgating2. Crawling3. Invalid direction
Operational Modes:	<ul style="list-style-type: none">• Entry and Exit• Entry Only• Exit Only• Free Exit• Free Entry• Evacuation mode



PRO WING® SPEEDSTILE RETRACTABLE

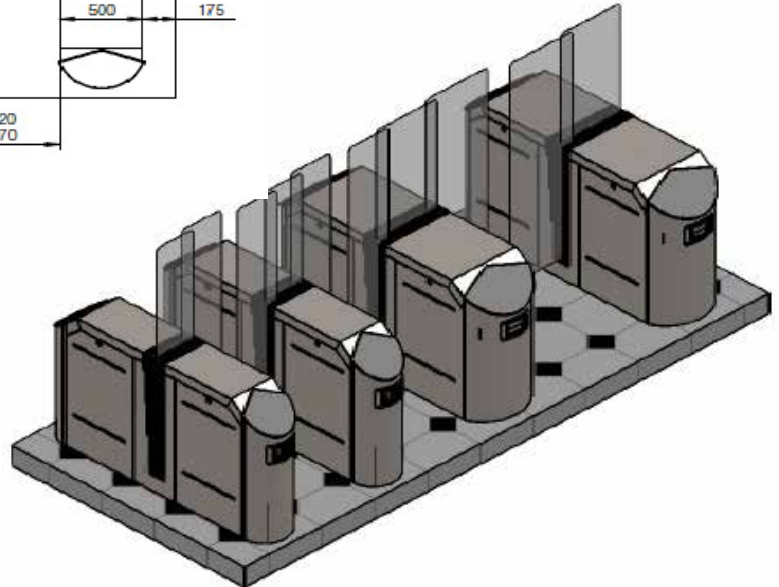
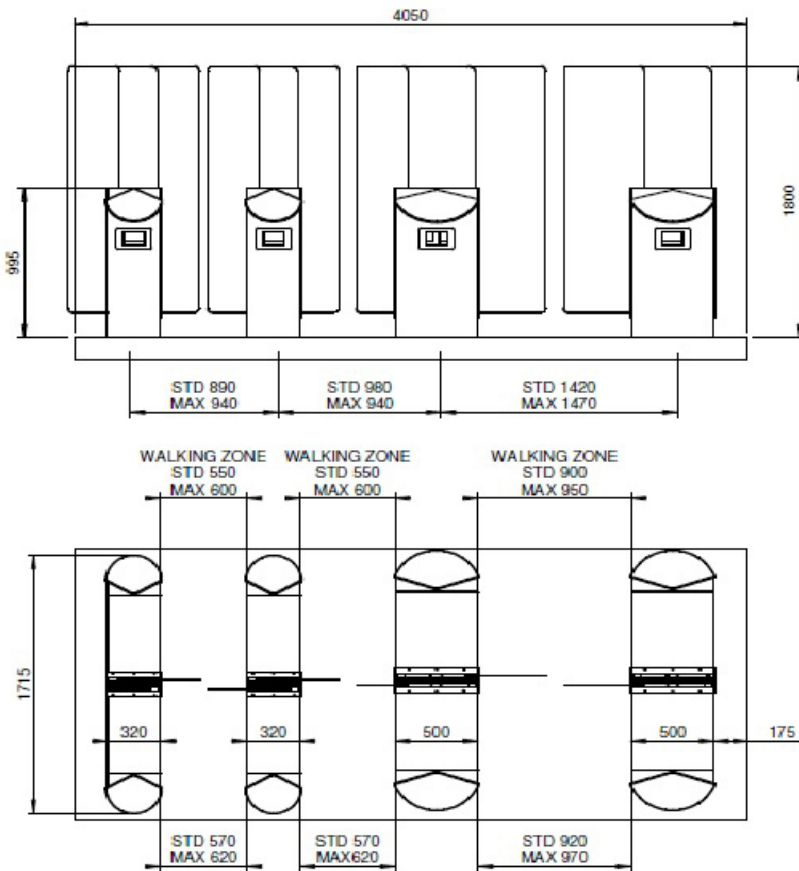

*Due to continuous improvement, products and design are subject to change without notice.

ASSOCIATED PRODUCTS



PRO WING® SPEEDSTILE 2 NARROW 1 WIDE AND MOTORIZED SWING

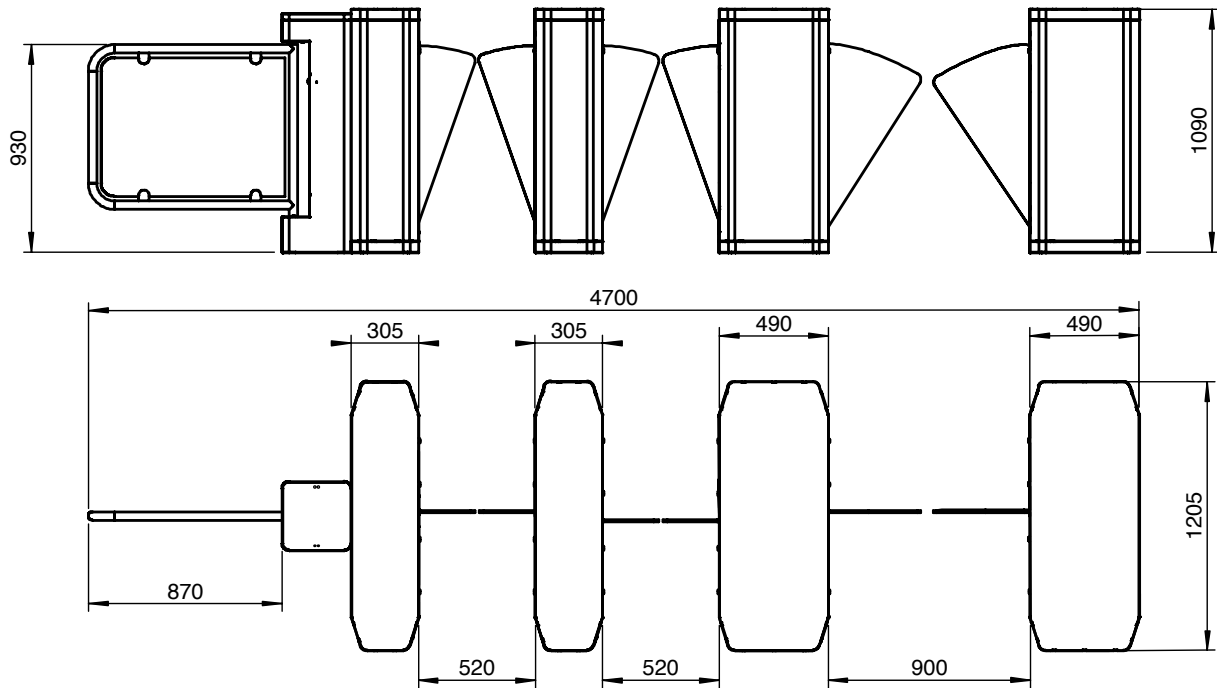

*Due to continuous improvement, products and design are subject to change without notice.

ASSOCIATED PRODUCTS



PRO WING® SPEEDSTILE 180° SWING GATE

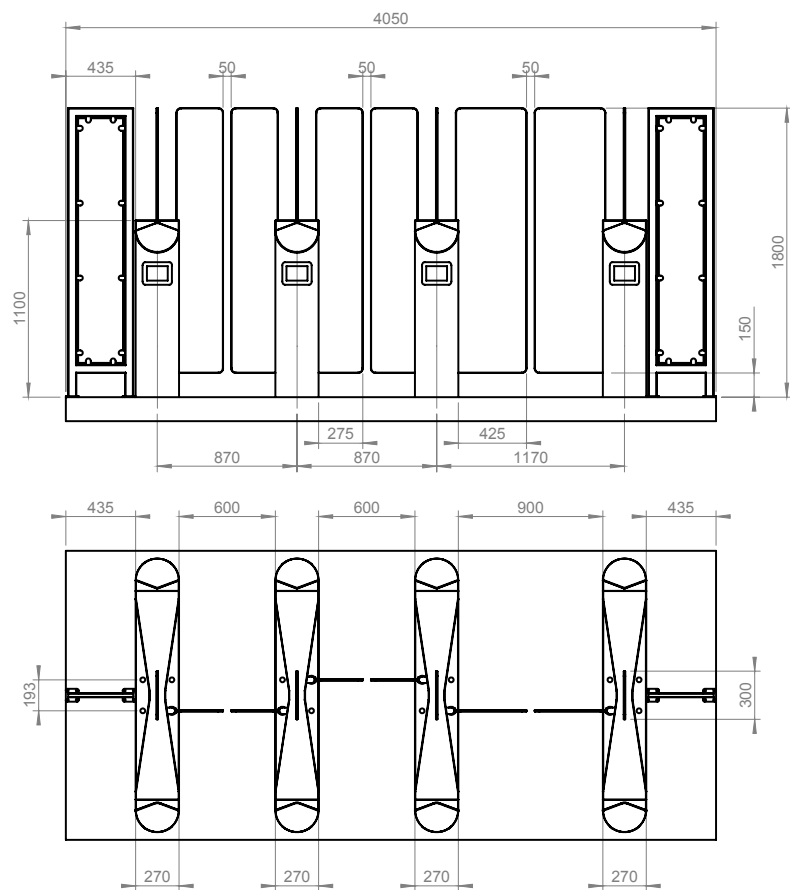

*Due to continuous improvement, products and design are subject to change without notice.



BoomGate[®]
Systems (PTY) LTD
Reg.No. 98/23505/07 Engineering Access Control



JOHANNESBURG BRANCH: Tel: +27 11 674 4441 • Fax: +27 11 674 4450 • Email: boomgate@global.co.za

18 Minerva Avenue, Leaglen, Florida, Roodepoort, SOUTH AFRICA

CAPE TOWN BRANCH: Tel: +27 21 551 0849 • Fax: +27 21 551 8627 • Email: salesct2@boomgatesystems.co.za

Unit 2 Crest Park, 12B Longclaw Drive, Montague Gardens, Cape Town, SOUTH AFRICA

www.boomgatesystems.co.za

Manufacturers & Suppliers of:

- Traffic Barriers • High Security Spike Barriers • Road Blockers • Turnstiles • Security Booths • Pedestrian Barriers
- Paraplegic Gates • Speed Gates • Bollards • Goosenecks • Magnetic Locks • Metal Enclosures • Rubber Islands

© Boomgate Systems (Pty) Ltd 2015