



TORNADO® 4-ARM HALF HEIGHT TURNSTILE



TECHNICAL QUALITY SPECIFICATIONS

- 1) Lockable top channel cover c/w 2 x locks
- 2) Top channel
- 3) New design mechanism c/w
 - a. 7 year warranty
 - b. Unique "keyless square shaft®"
 - c. Suspended rotor
 - d. Dust cover
- 4) Rotor cupling c/w 4 x shock absorbing rubbers
- 5) Rotor with 50mm x 25mm x 3mm rectangular tube spaced 150mm apart
- 6) Rotor centre guide
- 7) Side frame
- 8) Side screen
- 9) Cable entry
- 10) Reader mounting
- A) Floor mounting lugs x 16

SINGLE HALF HEIGHT TURNSTILE

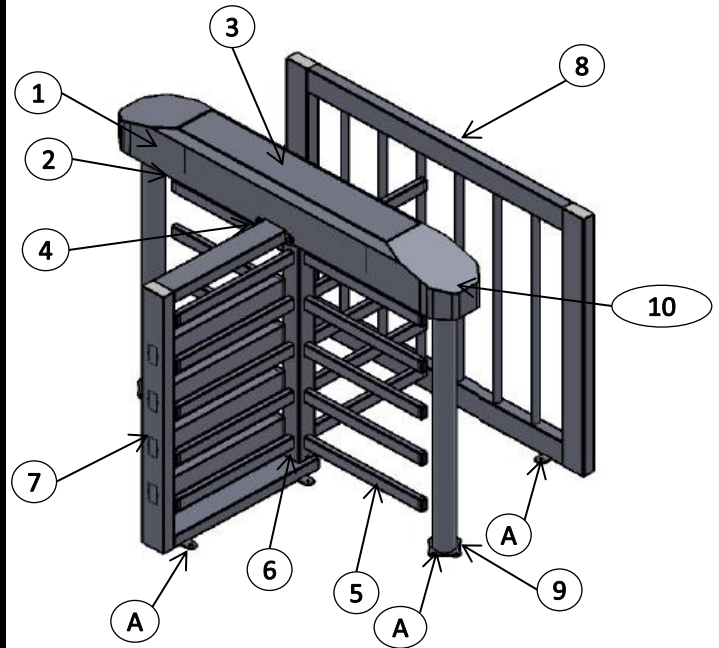

TECHNICAL QUALITY SPECIFICATIONS

- 1) Lockable top channel cover c/w 2 x locks
- 2) Top channel
- 3) New design mechanism c/w
 - a. 7 year warranty
 - b. Unique "keyless square shaft®"
 - c. Suspended rotor
 - d. Dust cover
- 4) Rotor cupling c/w 4 x shock absorbing rubbers
- 5) Rotor with 50mm x 25mm x 3mm rectangular tube spaced 150mm apart
- 6) Rotor centre guide
- 7) Rotor divider
- 8) Side screen
- 9) Cable entry
- 10) Reader mounting
- A) Floor mounting lugs x 16

DOUBLE HALF HEIGHT TURNSTILE

