

# TORNADO™ HALF HEIGHT TURNSTILES



**TECHNICAL BROCHURE**  
(4-ARM) SINGLES & DOUBLES

**BoomGate**  
**Systems** (PTY) LTD

Reg.No. 98/23505/07 Engineering Access Control



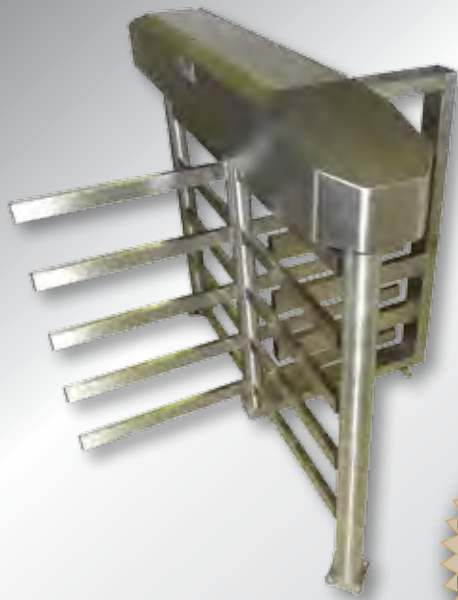

## MARKET LEADER:

- Now comes with new "Keyless Square Shaft®" design
- Used for reliability, ultra high traffic flow, virtually no maintenance
- Exported worldwide

## APPLICATIONS:

- 1 To control high volumes at medium risk areas.
- 2 Most suitable: mining, industrial, stadiums and warehouses.
- 3 Suitable for exterior and interior applications.
- 4 4-arm (90°).

## CONFIGURATIONS:

- 4-arm (90°)
- Single and Double
- Mild steel powder coated
- Mild steel galvanised
- Stainless steel 304
- Stainless steel 316

## SECURITY LEVEL RATING: (LOW / MEDIUM / HIGH / ULTRA SECURE)

TYPE	TORNADO®	LOW	MEDIUM	HIGH	ULTRA SECURE
4-ARM	SINGLE/DOUBLE	X			

## DEFINITION:

**Security rating** is based on when the turnstile is in the locked position.

**Level of security** is based on entry through the turnstile without unlocking the rotor and the use of access control system.



## SPECIAL FEATURES TO THE TORNADO™ HALF HEIGHT TURNSTILE RANGE:

- Unique “keyless square shaft” design.
- This new design in our shaft is what sets us apart.
- Designed for long-lasting reliability.
- Rotor returns to locked position after every rotation.
- Modular 11 pin programmable logic with LED indicators.
- Control panel comes standard with 12V and 24V DC output.
- Mechanical key override for both directions.
- Solenoids are rated 100% duty cycle for trouble free operations.
- Case hardened locking mechanism.
- Maintenance free mechanism.
- Rotor arm 50 x 25mm.
- Readers can be mounted to frame.
- Factory tested recorded serial numbers.
- Quiet locking and unlocking mechanism.
- Manufacturers warranty
  - **7 year mechanical warranty - first in S.A.**
  - **1 year electrical warranty**
- Zinc plated mechanism for corrosive protection.
- Mechanism comes with a dust cover for extra protection, noise reduction.
- Draw wires are supplied to reader boxes.

### DID YOU KNOW:

- Your turnstile comes with a 7 year mechanical warranty, the first in S.A. That is how confident we are in our product.
- You will not pay for any mechanical component in your 7 year warranty period.
- BGS has been manufacturing turnstiles for 16 years.
- Our customers range from world renowned blue chip corporations to small single users.
- BGS turnstiles are supplied complete with control panel. The control panel is suitable for battery back up. Batteries are not included. Need 2 x 7.5 amp/hour. Battery back up option comes standard on all our models at no extra cost.
- The control panel also has a 12V output for LED indicators.
- All mechanical components are Die Cast, CNC machined and laser cut to the highest precision and quality.
- Turnstile comes standard with reader boxes with draw wires.



## TECHNICAL SPECIFICATIONS:

### ELECTRICAL REQUIREMENTS:

<b>Power:</b>	220V AC $\pm$ 5%
<b>Frequency:</b>	50Hz
<b>Power Consumption:</b>	50W for single turnstile and 100W for double turnstile
<b>Logic Voltage:</b>	24V DC, 12V available on request
<b>Solenoids Voltage:</b>	24V DC, 12V available on request
<b>Turnstile Dimensions:</b>	See drawings overleaf
<b>Rotor arm configurations:</b>	4-arm = 90°
<b>Rotor arms:</b>	50 x 25mm diameter 130mm apart
<b>Weight:</b>	Single half height turnstile 4-arm = 160kg Double half height turnstile 4-arm = 250kg
<b>Export:</b>	Turnstile can be disassembled and packed into purpose made pallets for export. Materials are treated for export.

### SYSTEM COMPATIBILITY:

Boomgate Systems turnstiles are compatible with any access control, time and attendance system or ticketing system. Only requires a n/o voltage free input trigger set for half a second.



### ROTOR ASSEMBLY Strongest in the Industry



## AVAILABLE OPTIONS:

### Single/Dual

#### Direction Rotation:

Electronic control in one direction and mechanical in opposite direction.

Electronically controlled in both directions.

Mechanical control in both directions by means of key lock.

#### Power Locking Options:

Fail secure lock on power failure.

Fail safe unlock on power failure.

#### Fire Evacuation Option:

Rotor will free turn when input is triggered. (It is not recommended to use a turnstile for emergency evacuation).

#### Battery Back Up:

Battery back up comes standard with all our turnstiles. Batteries not included. Requires 2 x 7aH batteries to be connected in series. A third battery can be added for 12V back up.

± 1000 transactions on fail secure mode.

± 60 minutes on fail safe mode.

#### Indication LED:

The turnstile can be fitted with red/green walking man to indicate go or stop.

#### Card reader brackets:

The turnstile comes standard with card reader brackets.

#### Accessories available on request:

Bigger reader boxes, rain covers, push buttons, coin acceptors for paid access control, random search selectors.

#### Material options:

Mild steel powder coated with textured exterior UV resistant powder.

Mild steel hot dip galvanised.

Mild steel hot dip galvanised and powder coated.

304 stainless steel brushed.

316 stainless steel brushed for extreme conditions.

Standard colours are blue hammertone.



# TORNADO™ 4-ARM HALF HEIGHT TURNSTILE



**SINGLE HALF HEIGHT TURNSTILE**

**DOUBLE HALF HEIGHT TURNSTILE**

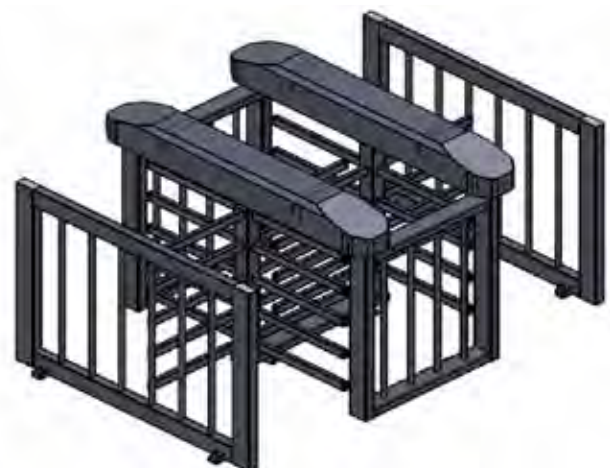
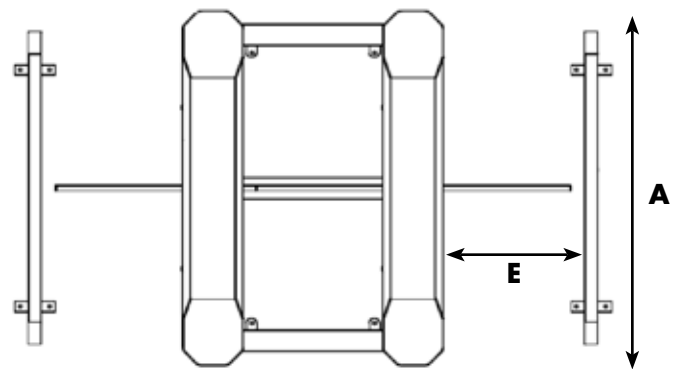
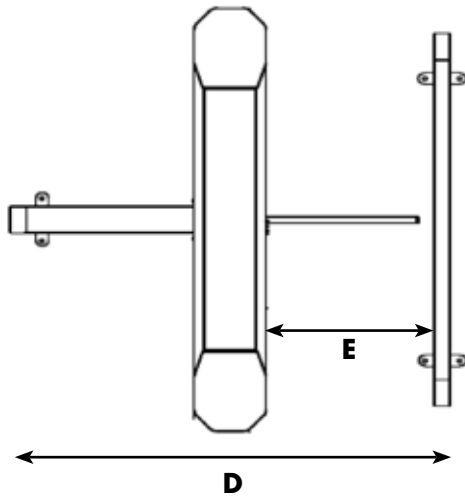
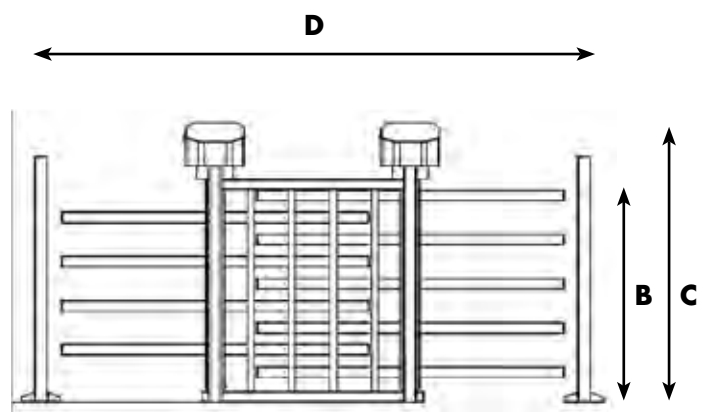
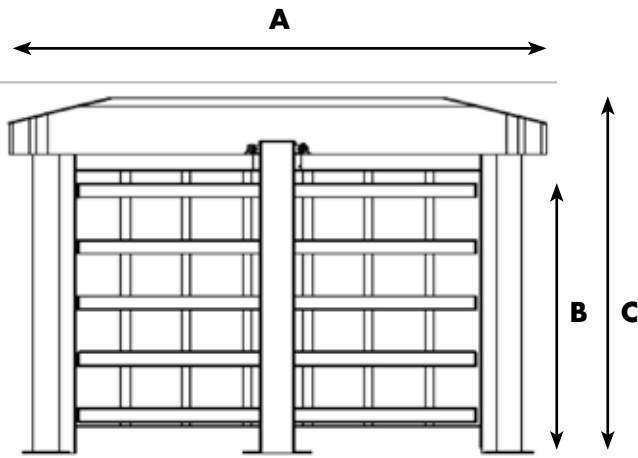

A	Overall Width	1590mm
B	Rotor Arm Height	860mm
C	Overall Height	1270mm
D	Overall Depth	1380mm
E	Rotor Arm Length	530mm

A	Overall Width	2136mm
B	Rotor Arm Height	860mm
C	Overall Height	1270mm
D	Overall Depth	1590mm
E	Rotor Arm Length	530mm

Due to continuous improvement, products and design are subject to change without notice.



## TORNADO™ 4-ARM SINGLE HALF HEIGHT

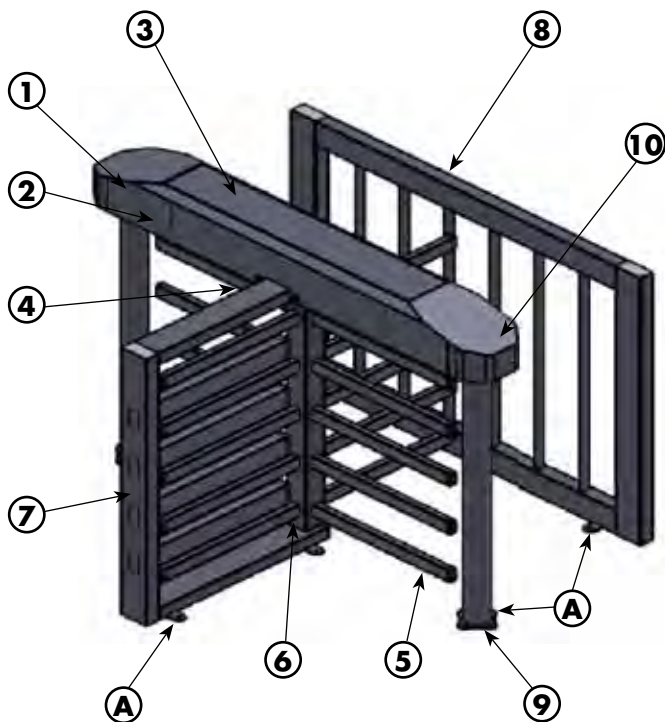

- 1 Lockable top channel cover c/w 2 x locks
  - 2 Top channel
  - 3 New design mechanism c/w
    - a. 7 year warranty
    - b. Unique keyless square shaft™
    - c. Suspended rotor
    - d. Dust cover
  - 4 Rotor cupling c/w 4 x shock absorbing rubbers
  - 5 Rotor with 50 x 25mm x 3mm rectangular tube spaced 130mm apart
  - 6 Rotor centre guide
  - 7 Side frame
  - 8 Side screen
  - 9 Cable entry
  - 10 Reader mounting
- A Floor mounting lugs x 16

## TORNADO™ 4-ARM DOUBLE HALF HEIGHT

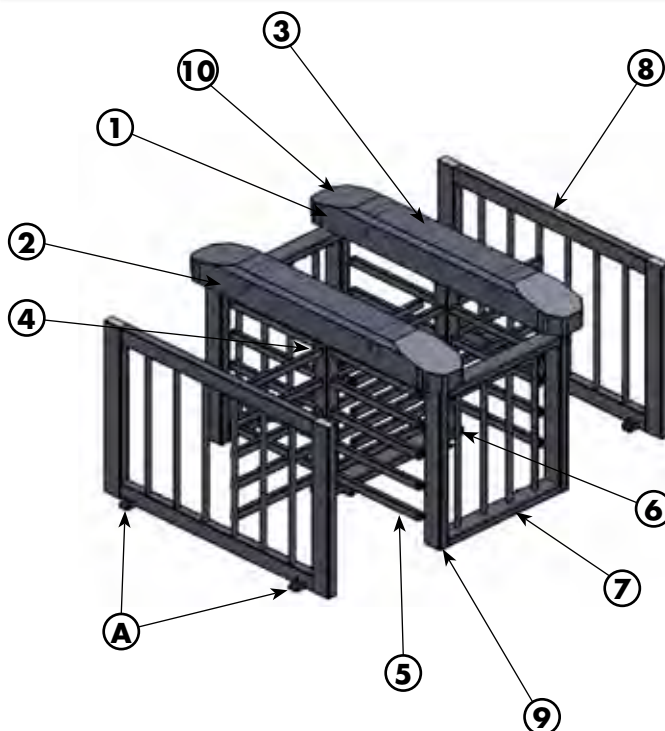

- 1 Lockable top channel cover c/w 2 x locks
  - 2 Top channel
  - 3 New design mechanism c/w
    - a. 7 year warranty
    - b. Unique keyless square shaft™
    - c. Suspended rotor
    - d. Dust cover
  - 4 Rotor cupling c/w 4 x shock absorbing rubbers
  - 5 Rotor with 50 x 25mm x 3mm rectangular tube spaced 130mm apart
  - 6 Rotor centre guide
  - 7 Rotor divider
  - 8 Side screen
  - 9 Cable entry
  - 10 Reader mounting
- A Floor mounting lugs x 16

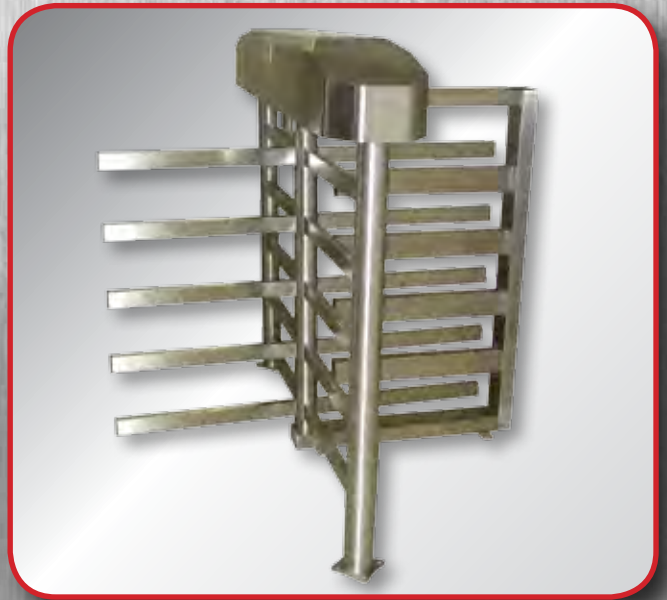

**BoomGate**<sup>®</sup>  
**Systems** (PTY) LTD

Reg.No. 98/23505/07 Engineering Access Control



**JOHANNESBURG BRANCH: Tel:** +27 11 674 4441 • **Fax:** +27 11 674 4450 • **Email:** boomgate@global.co.za

18 Minerva Avenue, Leaglen, Florida, Roodepoort, SOUTH AFRICA

**CAPE TOWN BRANCH: Tel:** +27 21 551 0849 • **Fax:** +27 21 551 8627 • **Email:** salescf2@boomgatesystems.co.za

Unit 2 Crest Park, 12B Longclaw Drive, Montague Gardens, Cape Town, SOUTH AFRICA

[www.boomgatesystems.co.za](http://www.boomgatesystems.co.za)

**Manufacturers & Suppliers of:**

- Traffic Barriers • High Security Spike Barriers • Road Blockers • Turnstiles • Security Booths • Pedestrian Barriers
- Paraplegic Gates • Speed Gates • Bollards • Goosenecks • Magnetic Locks • Metal Enclosures • Rubber Islands