

Dimensions

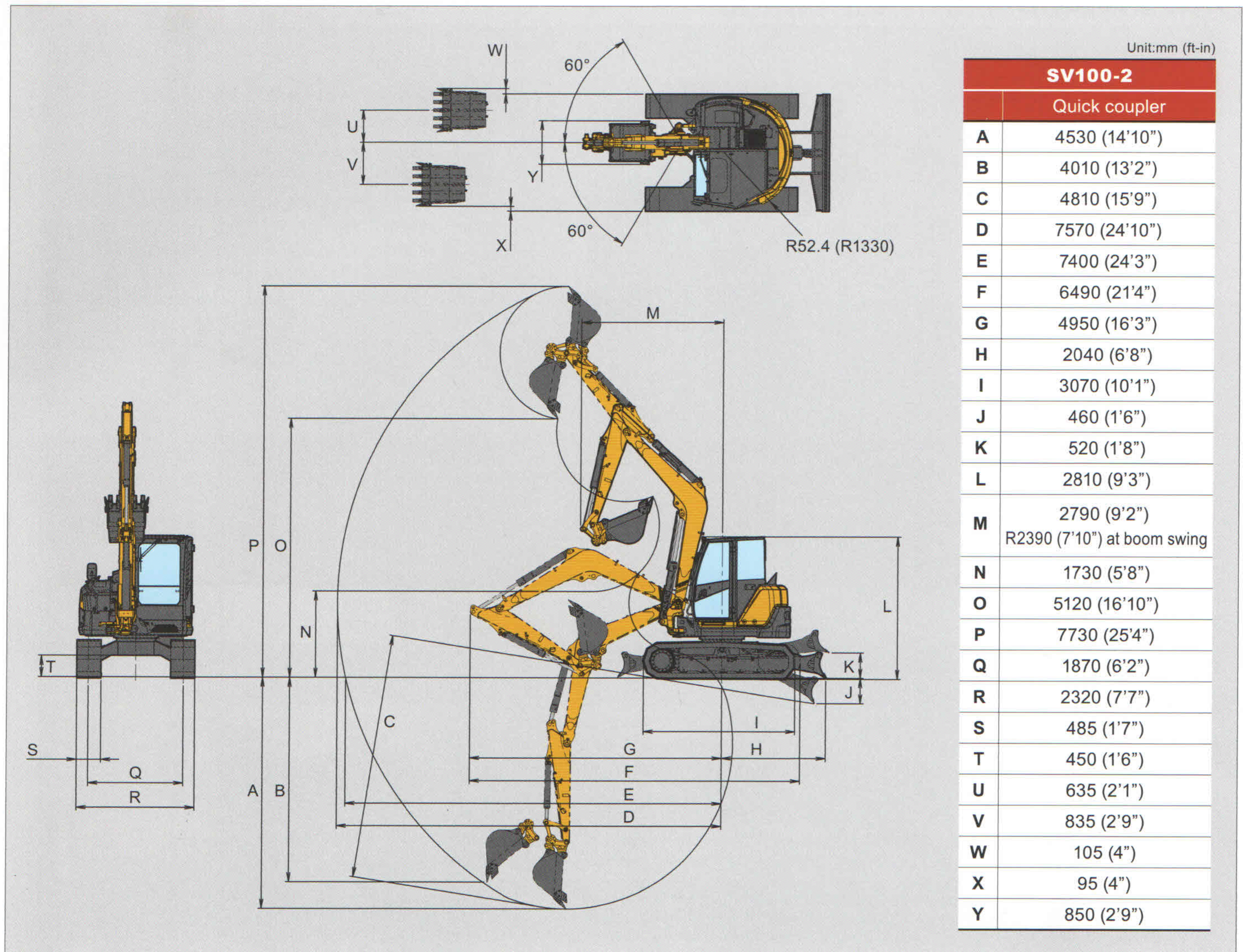

Specifications

Model		SV100-2	
Type		Cab. rubber track	Cab. steel track
Operating weight		lbs (kg)	21550 (9775) / 21660 (9825)
Engine	Type	Vertical four cylinder water-cooled direct injection diesel engine	
	Model	4TNV98T-ZSBV2	
	Rated output	HP (kW) / rpm	73.3 (54.7) / 2200
Performance	Maximum digging force (bucket) / arm	lbs. (kN)	12216 (54.3) / 4500 (42.3)
	Travel speed: high / low	MPH (km / h)	2.7 (4.4) / 1.6 (2.5) / 2.5 (4.0) / 1.4 (2.2)
	Swing speed	rpm	9.1
	Boom swing angle : left / right	degrees	60 / 60
	Gradability	degrees	30
Ground contact pressure		PSI (kPa)	5.5 (37.9) / 5.6 (38.8)
Hydraulic system	Hydraulic pump displacement	GPM (L / min)	20.5 (77.7) X2 <Variable displacement pump> / 15.2 (57.5) X1, 5.3 (20) X1 <Gear pump>
	System relief set pressure	PSI (MPa)	3988X2, 3481X1, 421X1 (27.5X2, 24.0X1, 2.9X1)
Blade dimensions	Width	mm (ft-in)	2320(7'7")
	Stroke,raise / lower from G.L.	mm (ft-in)	520 (1'8") / 460 (1'6") / 495 (1'7") / 485 (1'7")
Fuel tank capacity			115

Hydraulic PTO

Model		SV100-2	
Specification	Output	PSI (kPa)	GPM (L / min)
			2100RPM
Combined flow, double actions		3988 (27.5)	34.3 (130) / 19.8 (75)